

Express Kennel Uses

REV	DATE	DESCRIPTION	DRW	APP

Temporary Boarding Space

1. Peak Seasons - return to storage when not in use
2. Fill kennels for 30 days and they pay for themselves
3. Doggy Day Care - time outs
4. Intake kennels - Streamline check-in / check-out process by setting up in a convenient area
5. Perfect for use in leased space - easy to take with when you move.
6. Quarantine/Isolation Suites (break down easily for deep cleaning)
7. Veterinary rehab / recovery kennels
8. Dog Staging area for pet shows and events (lockable)

Permanent Boarding Solutions

1. High density boarding for large and small dogs
2. Grooming Salon drying kennels
3. High end training kennel, Customer can take home with a trained dog for a continuous "home"
4. Veterinary clinic boarding
5. Sporting / working dog premium kennel
6. Personalized, premium home kennel (put your dogs name or a logo on the door)

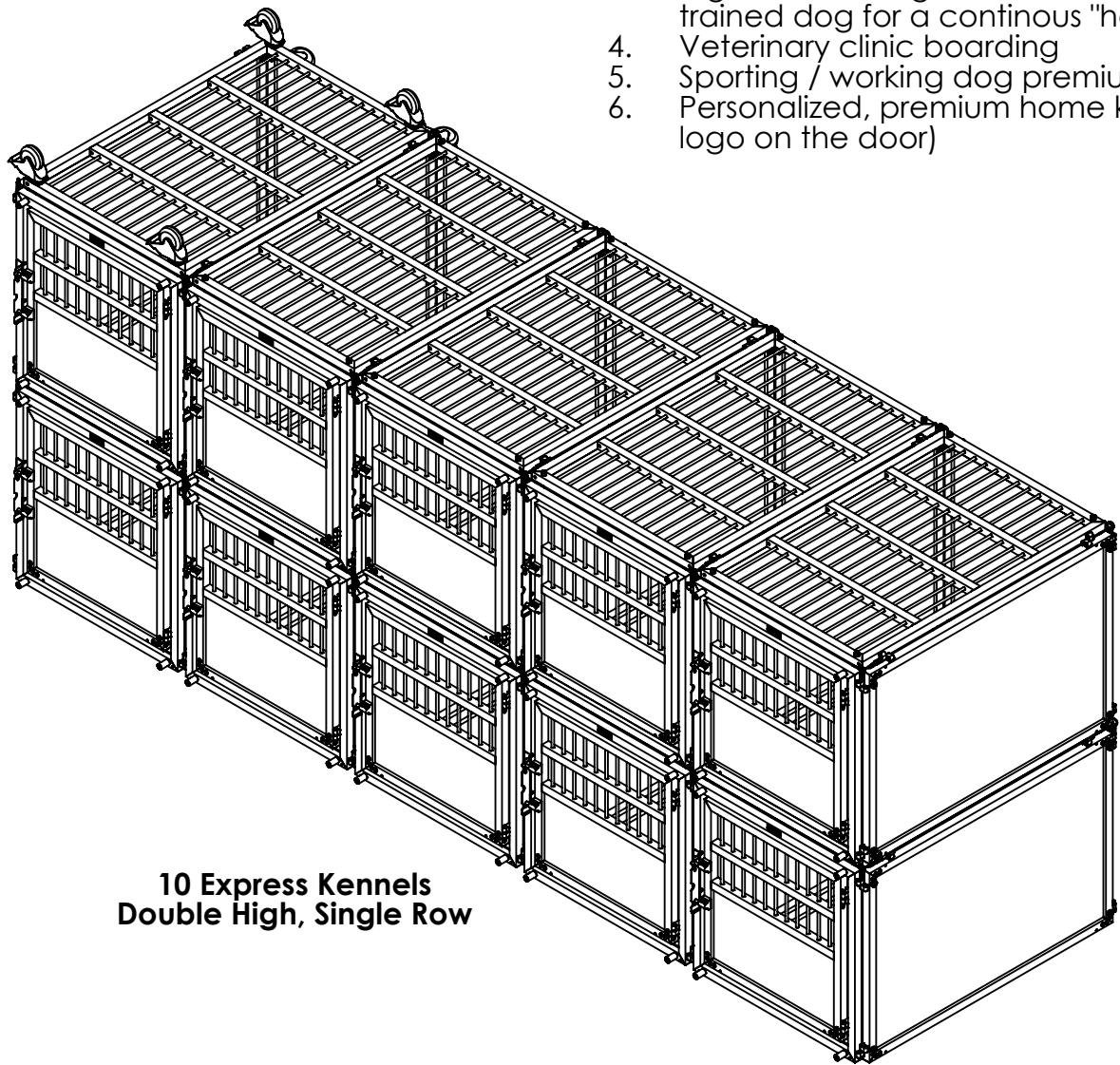

**10 Express Kennels
Double High, Single Row**

Innovative Patent Pending Design Quick & easy Setup, Take down and Storage

1. Make the best use of limited space with up to 4X the lodging density of cheap wire crates, designed for double high, side by side and back to back
2. Can be configured as single or double high, side by side and back to back
3. Less than 1 hour setup time for 10 kennels
4. No tools required or loose parts to keep track of
5. Up to 15 kennels break down into two convenient, stacking carts for storage using built in casters
6. carts fit through a standard 36" door
7. Top, sides and trays cart has a footprint of 46.75" x 32"
8. Gates and backs cart has a footprint of 31.5" x 30.5"
9. Casters can remain in place when assembled for convenience or removed for permanent installations.

Heavy Duty, Attractive, Commercial Grade Kennels

1. Standard size (32" x 32" x 48") is spacious and comfortable for large and small dogs
2. Tough to use everyday, year round as permanent boarding kennels
3. Premium anodized aluminum framework for beautiful and durable finish
4. All Stainless Steel attachment hardware.
5. Tough 1/4" thick HDPE panels are available in 3 colors blue, tan and evergreen
6. Heavy gage (.25") ABS trays contain accidents and are removable for cleaning.
7. 3 gate styles are available - full grill, half panel, solid panel
8. Custom engraving option available for company logo, dog's name etc.
9. Lockable latch for security
10. Optional Kuranda bed fits inside
11. Optional bowls on inside of door
12. Optional baskets on outside of door
13. Optional casters for portability
14. Made in the USA

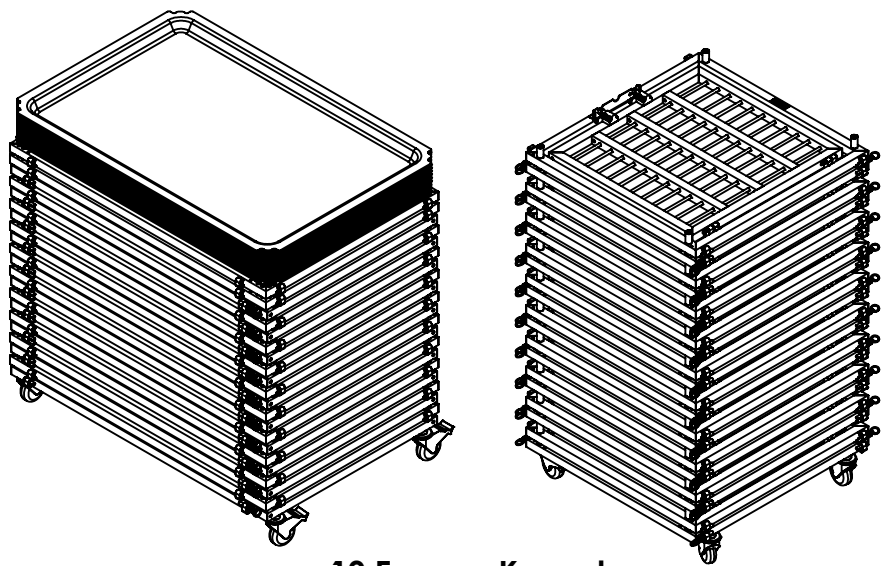

**10 Express Kennels
Collapsed for Storage**

		LARSON SYSTEMS INC.			
		10073 Baltimore St. NE PH. 763-780-2131 Mpls., MN 55449 FAX. 763-780-2182			
		APPROVALS	DATE	Express Kennel Assembly	
		DRAWN DAL	01/15/2014		
APP.	APP.				
SCALE: NONE		B DWG. NO. 025-0000-0944-00A	REV:		
SHEET 1 OF 6					

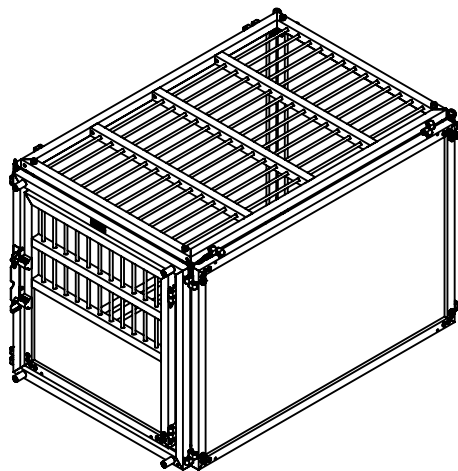

Single Express Kennel

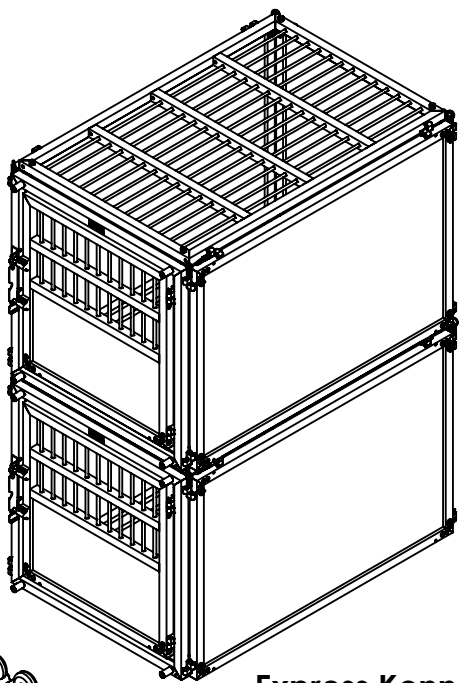

Express Kennels
Double High

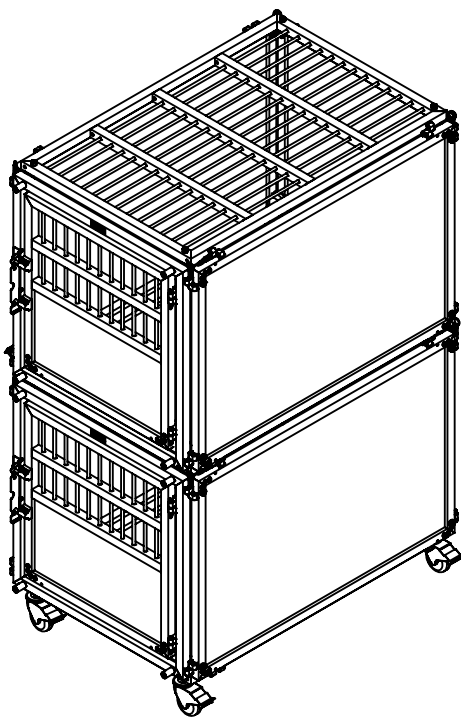

Express Kennels
Double High, Movable

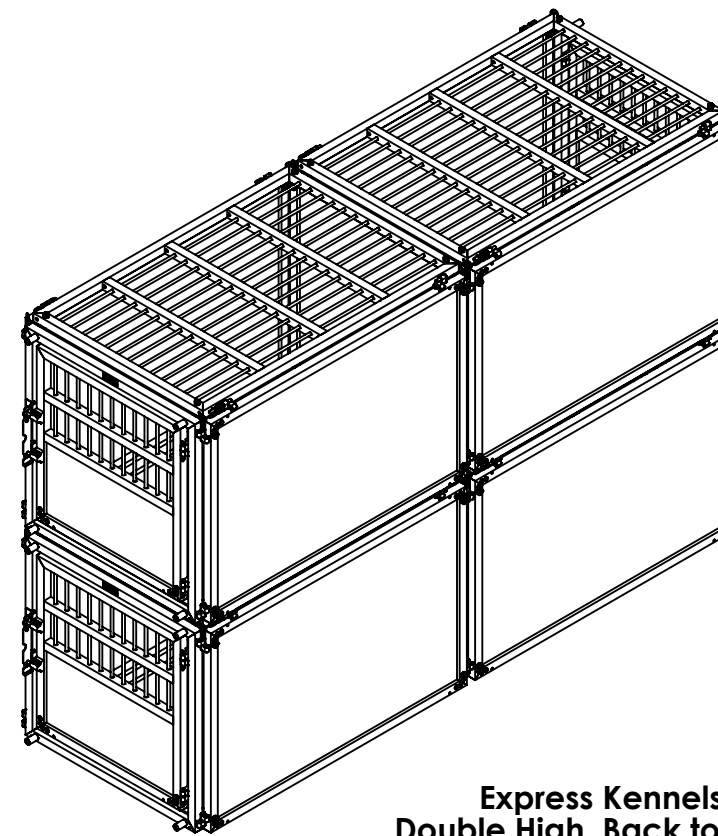

Express Kennels
Double High, Back to Back

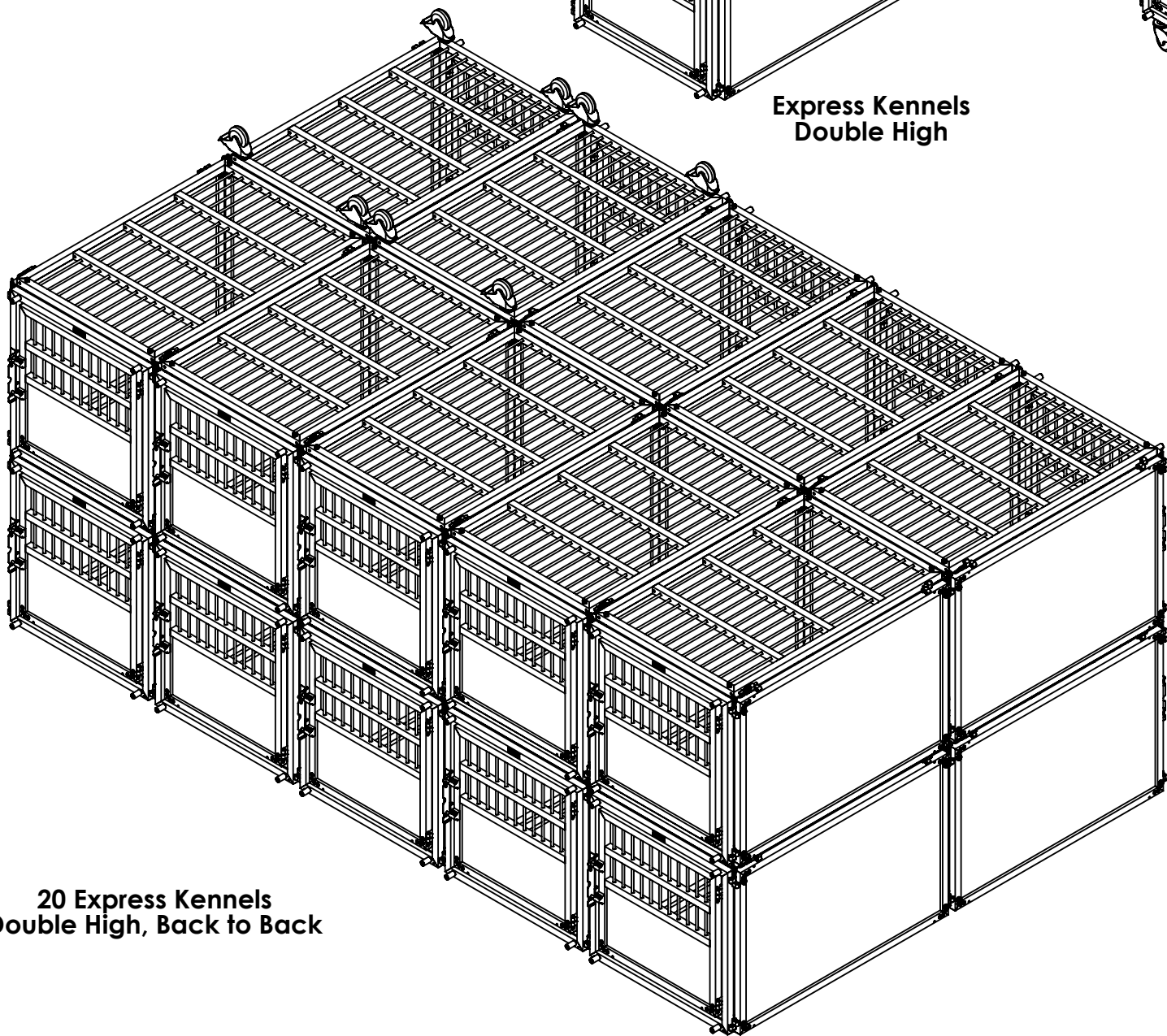

20 Express Kennels
Double High, Back to Back



LARSON SYSTEMS INC.

10073 Baltimore St. NE PH. 763-780-2131
Mpls., MN 55449 FAX. 763-780-2182

APPROVALS	DATE		
DRAWN DAL	01/15/2014	Express Kennel Assembly	REV:
APP.		B DWG. NO. 025-0000-0944-00A	
APP.		SCALE: NONE	SHEET 2 OF 6

Just pull spring pin, No tools
or loose parts for assembly
or disassembly

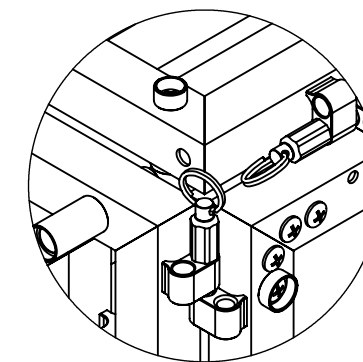

DETAIL A
SCALE 1 : 4

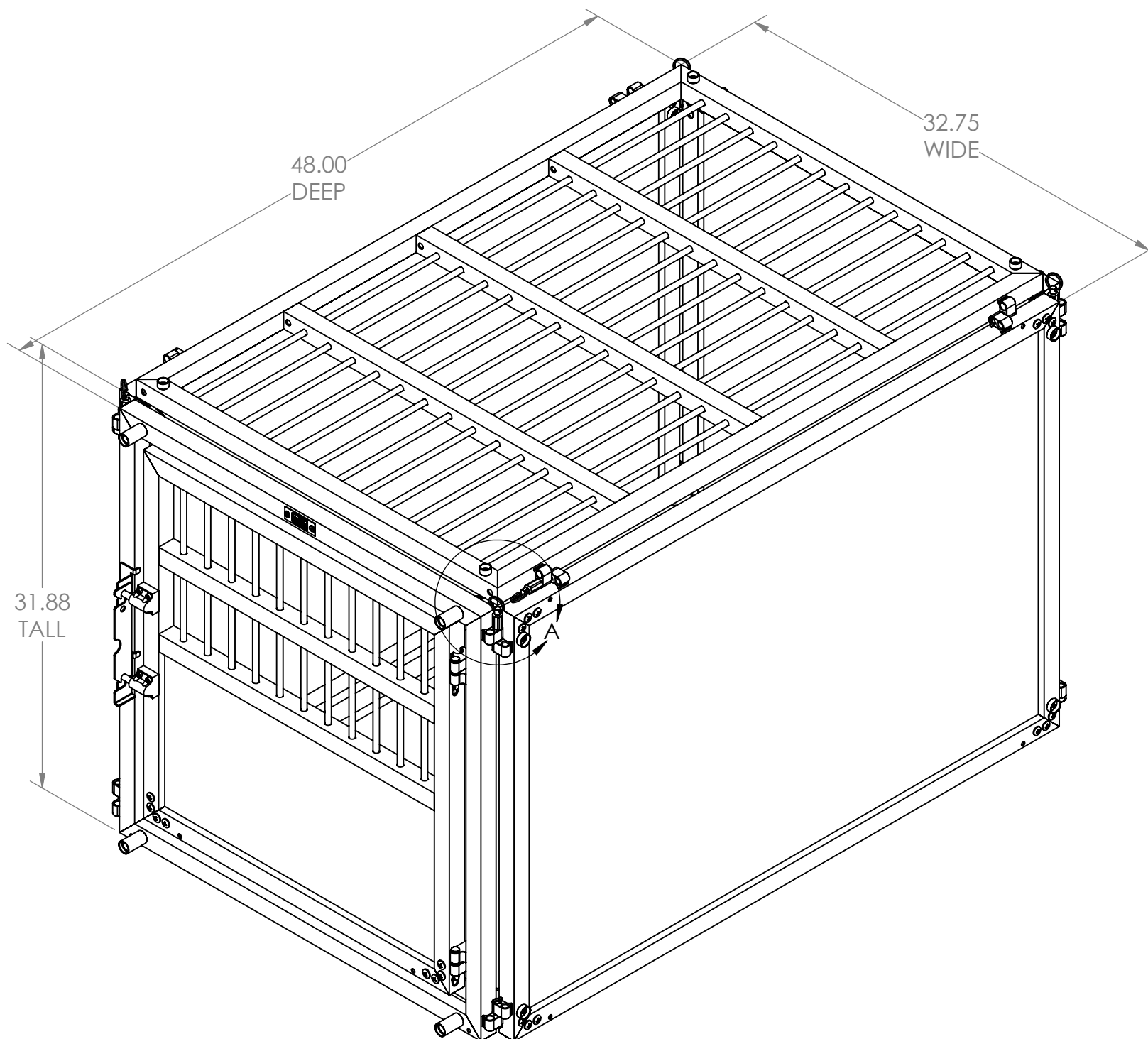

		LARSON SYSTEMS INC.	
		10073 Baltimore St. NE PH. 763-780-2131 Mpls., MN 55449 FAX. 763-780-2182	
APPROVALS	DATE		
DRAWN DAL	01/15/2014	Express Kennel Assembly	
APP.		B	DWG. NO. 025-0000-0944-00A
APP.		SCALE: NONE	REV: SHEET 3 OF 6

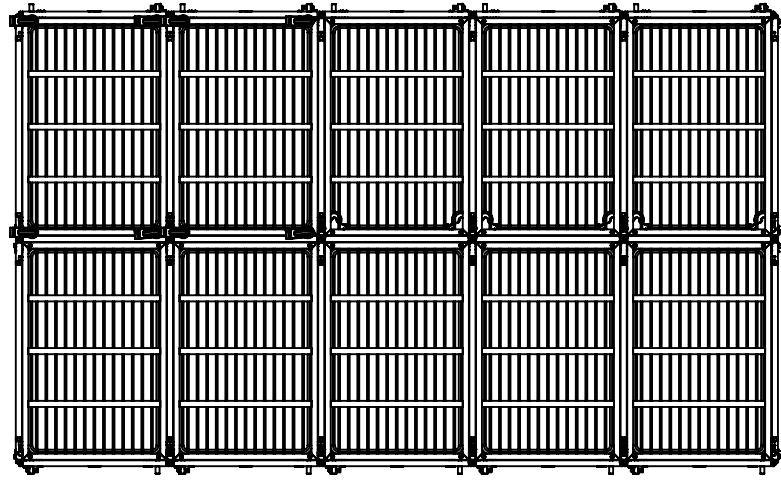

TOP VIEW

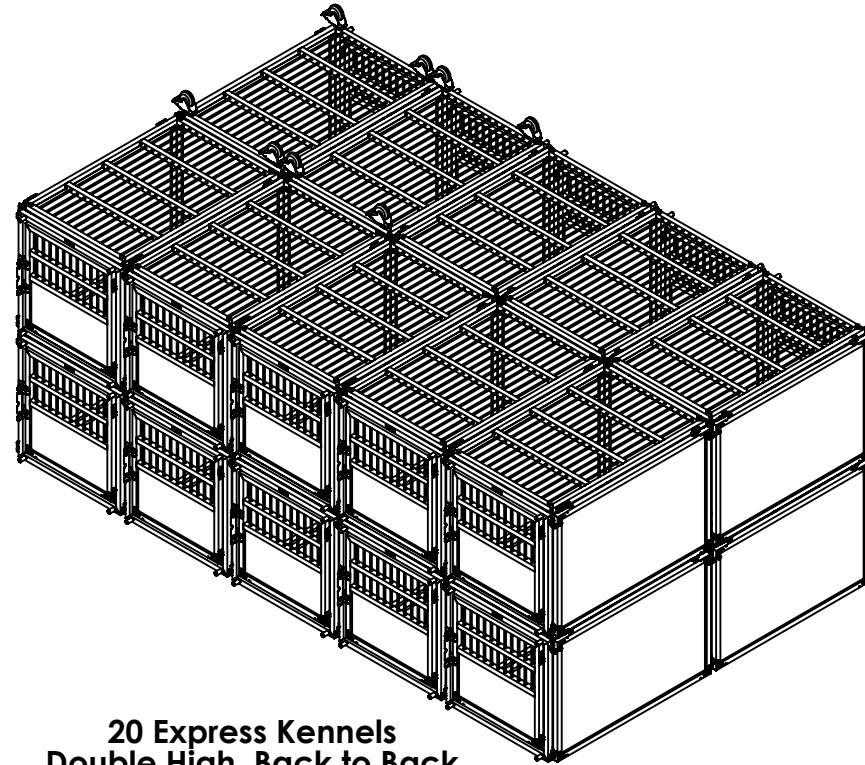

**20 Express Kennels
Double High, Back to Back**

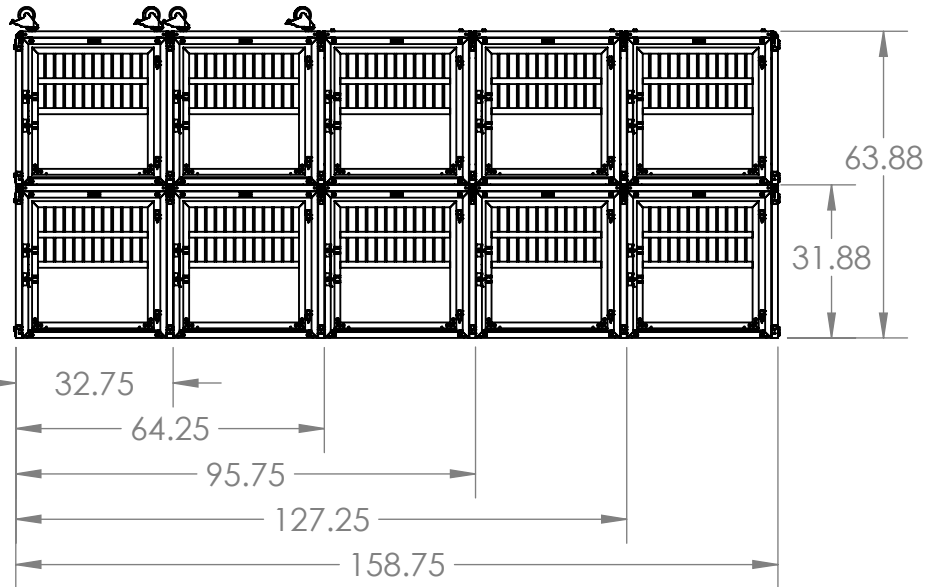

FRONT VIEW

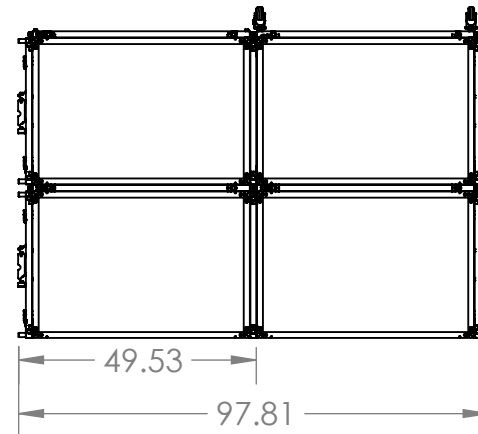

SIDE VIEW

Storage Footprint

Gates / Backs

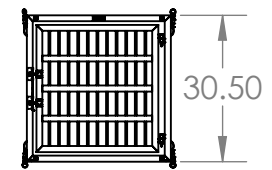

Sides / Tops / Trays

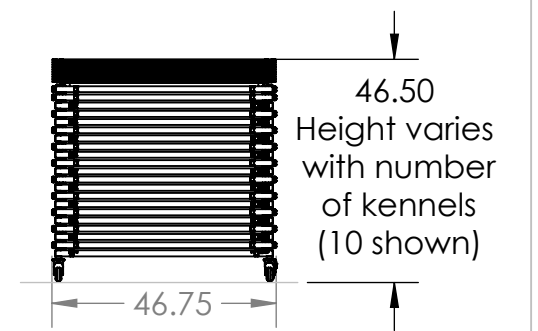
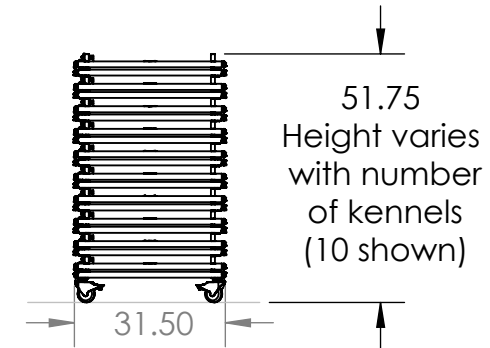
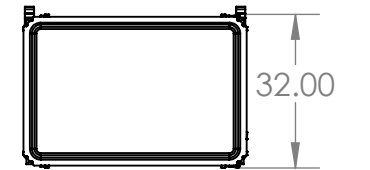

LARSON SYSTEMS INC.

10073 Baltimore St. NE PH. 763-780-2131
 Mpls., MN 55449 FAX. 763-780-2182

APPROVALS	DATE		
DRAWN DAL	01/15/2014	Express Kennel Assembly	
APP.		B	DWG. NO. 025-0000-0944-00A
APP.		SCALE: NONE	REV: SHEET 4 OF 6

Express Kennel Components

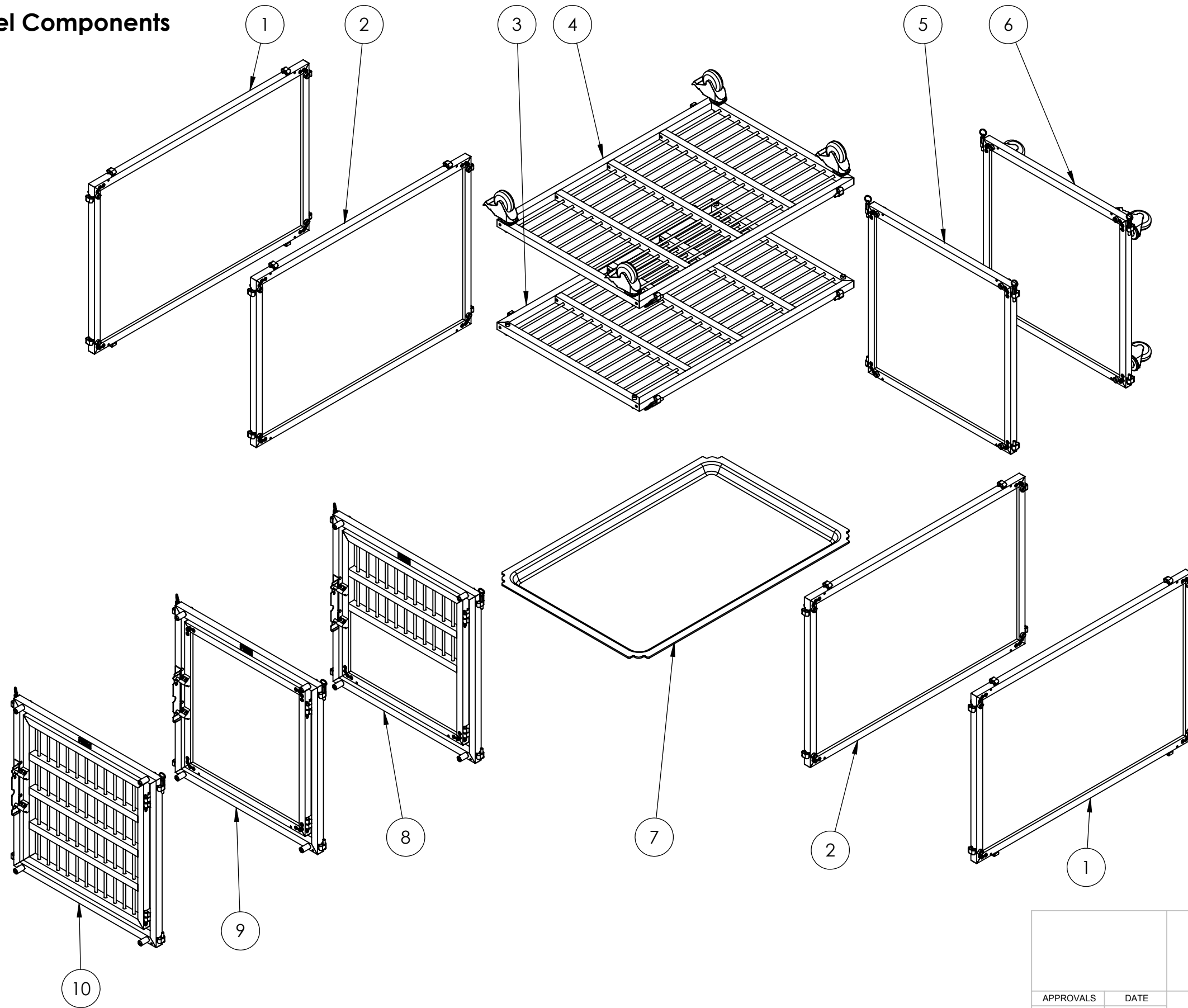

APPROVALS		DATE	
		DRAWN DAL	1/15/2014
APP.		B	DWG. NO. 025-0000-0944-00A
APP.			REV:
SCALE: NONE			SHEET 5 OF 6

LARSON SYSTEMS INC.

10073 Baltimore St. NE
Mpls., MN 55449

PH. 763-780-2131
FAX. 763-780-2182

Express Kennel Assembly